



**COUGAR**<sup>®</sup>  
INDUSTRIES, INC.

---

**PNEUMATIC  
PISTON  
VIBRATORS**



# PNEUMATIC PISTON VIBRATORS

In 2001, Cougar Industries, Inc. purchased the Branford Vibrator Company and now manufactures their wide range of piston vibrators.

Piston vibrators are commonly used as flow aids on bins, hoppers, chutes and have also been used successfully as drives for vibrating tables, vibratory feeders and screens. Ease of attachment, high force output and adjustability make them useful for a wide variety of applications.

- Alloy steel bodies are machined and honed to a precise tolerance and then fitted with a **hardened** piston.
- An internal **spring** assures positive starting in all positions.
- **Dust-Proofers**, standard on Series 5000 vibrators, reduce the noise level and prevent contaminants from entering the vibrator.

- A special **moly-coat** on the piston allows for efficient running. Additional lubrication can be added to further improve the performance and service life of the vibrator.

Piston vibrators require a quick opening valve to start. The valve can be a manual type or electrically controlled by a solenoid valve activated by a manual switch, push button or an electronic timer. The valve should be located within ten feet (hose length) of the vibrator. The air supply should have a filter, and regulator, mounted between the vibrators and the air compressor. The filter keeps the air clean and dry. The regulator allows adjustment of the air pressure to vary the force and frequency of vibration.

## CONSTRUCTION AND OPERATION

The Series 5000 piston vibrators are moly coated to reduce the need for additional lubrication. All pistons vibrators include an internal spring and dust-proofers.

## HIGH IMPACT VIBRATORS

This standard model provides much higher impact than competitive end-mounting vibrators and yet it is lighter in weight. Precise tolerances result in reduced air consumption and increased efficiency.

## AIR CUSHIONED (-AC) VIBRATORS

This model is utilized in areas where noise is objectionable and may affect production. Its high thrust action permits operation at low air pressures. When used in place of an impacting model, the next larger size should be employed.

## HIGH AMPLITUDE (L) VIBRATORS

Certain applications require low impact but a high reciprocating momentum action. These requirements can be satisfied through the use of High Amplitude Models. This type of action is usually necessary for the movement of dry materials of low density.

## UNIVERSAL MOUNT (-U) VIBRATORS

This series, which incorporates all of the features and benefits of our standard Series 5000 flange mount piston vibrator, is designed to be a direct bolt in replacement for all of the major manufacturers of flange mount piston vibrators. See separate interchange chart for specific model replacement.

## HIGH TEMPERATURE (-HT) OPTION

This option is used in applications where the temperature exceeds 250°F. The -HT option extends the maximum operating temperature to 400°F.

## VIBRATOR OPTION FOR THE ABOVE VIBRATORS:

-HT High Temperature

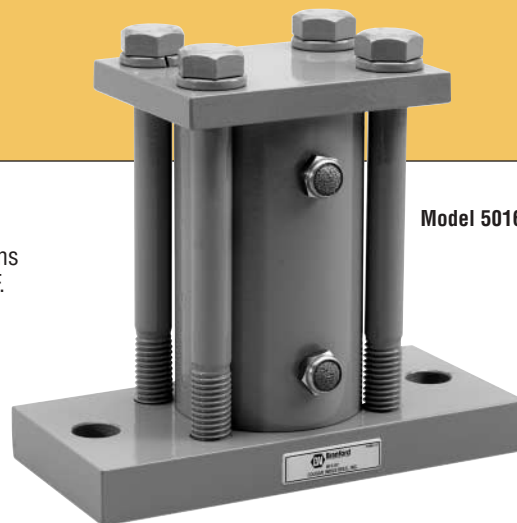

Model 5016

## PERFORMANCE

Series 5000 impacting

MODEL	PISTON DIA	40 PSI		60 PSI		80 PSI	
		VPM	CFM	VPM	CFM	VPM	CFM
5008	1"	5800	3.4	9500	5.6	11500	6.08
5010	1-1/4"	3500	6.1	5250	10.4	6500	14.4
5012	1-1/2"	2800	5.3	3500	8.1	4100	10.9
5016	2"	2600	11	3900	16.1	4100	20.9
5016L	2"	1400	6.8	2600	12.8	3500	19.7
5024	3"	2100	10.2	2600	16.7	3000	22.4
5024L	3"	850	13.6	1000	24.7	1250	35.9
5032	4"	1200	19.1	1700	31.8	1900	40.3
5032L	4"	700	20.4	950	31.9	1100	40.4

Series 5000 air cushioned

MODEL	PISTON DIA	40 PSI		60 PSI		80 PSI	
		VPM	CFM	VPM	CFM	VPM	CFM
5008-AC	1"	3900	3.4	4800	4.4	5500	5.8
5010-AC	1-1/4"	2900	6.8	3500	8.7	4000	11.6
5012-AC	1-1/2"	2350	6.2	2900	6.9	3400	10.9
5016-AC	2"	2250	6.8	2750	9.5	3200	12.5
5016L-AC	2"	1400	9.5	1700	14.3	2200	17.9
5024-AC	3"	2000	9.6	2100	15.2	2400	21.6
5024L-AC	3"	780	17.1	900	27.9	1200	35.9
5032-AC	4"	1200	13.7	1350	23.9	1700	35.9
5032L-AC	4"	650	20.5	750	27.9	900	35.9

**SIZING:** see page 7 – **MOUNTING:** see page 8 – **ACCESSORIES:** see page 9



## CONSTRUCTION AND OPERATION

Cougar High Energy Impactors are available in four sizes and feature an adjustable force that is regulated by controlling the air pressure from 10 to 80 psi. High Energy Impactors are most effective on sticky material because they are less likely to cause packing. These units make less noise and consume less air than standard piston vibrators because they do not run continuously. A timer, push button or Programmable Logic Controller, or any device capable of energizing a 3-way solenoid valve can activate High Energy Impactors.



## CONTROL TIMER

The Model TI-2 timed impact controller provides fully automated control of one or more LI High Energy Impactors. This is the most efficient means of uninterrupted production at a reduced labor cost. The solid-state control timer can be remotely located for operator convenience. Dimensions: 4-1/2" wide, 3-1/2" deep, 6" high, 115 volts. The part number for the control timer is found on page 9.

### Model LI-16

Shown with Installation & Operation Kit  
(includes: solenoid, hose assembly, mount channel, bolts, washers, nuts)

## PERFORMANCE

Series LI

MODEL	SIZE	KINETIC ENERGY AT 80 PSI	PULSE RATE/MIN MIN/MAX	AIR CONSUMPTION AT 80 PSI	
				CU.FT./STROKE	CU.FT./MIN
LI-10	1-1/4"	14 FT. LBS.	14/172	0.014	2.80
LI-16	2"	48 FT. LBS.	14/172	0.019	3.04
LI-24	3"	98 FT. LBS.	14/172	0.049	5.39
LI-32	4"	252 FT. LBS.	14/172	0.110	6.60

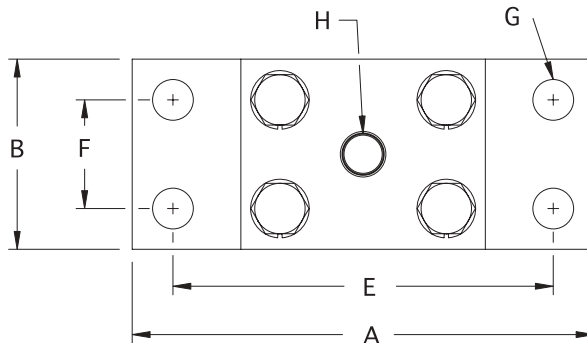
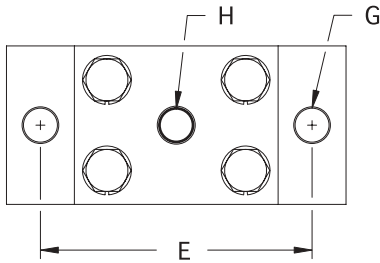
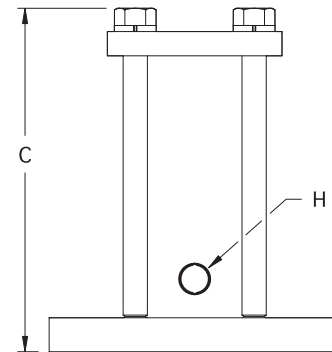

## DIMENSIONS

MODEL	PISTON DIA	LENGTH A	WIDTH B	HEIGHT C	BASE THK D	CC BOLT E	CC BOLT F	BOLT DIA. G	INLET PORT H	WEIGHT LBS.
5008/5008-AC	1"	4-1/2"	2"	4-3/8"	5/8"	3-1/2"	--	3/8"	1/8"	4.3
5010/5010-AC	1-1/4"	6"	2-1/2"	5-1/2"	3/4"	4-1/2"	--	1/2"	1/4"	8.2
5012/5012-AC	1-1/2"	7-1/2"	3"	7-1/8"	7/8"	6"	--	5/8"	1/4"	14.4
5016/5016-AC	2"	7-1/2"	3-1/2"	7"	7/8"	6"	--	5/8"	1/4"	20.0
5016L/5016L-AC	2"	7-1/2"	3-1/2"	8-3/4"	7/8"	6"	--	5/8"	1/4"	24.0
5024/5024-AC	3"	10-1/2"	4-1/2"	8-3/4"	1"	8-7/16"	2-1/2"	5/8"	1/2"	44.0
5024L/5024L-AC	3"	10-1/2"	4-1/2"	13-1/8"	1"	8-7/16"	2-1/2"	5/8"	1/2"	62.0
5032/5032-AC	4"	10-1/2"	5-1/2"	11-5/8"	1"	8-7/16"	2-1/2"	7/8"	1/2"	69.2
5032L/5032L-AC	4"	10-1/2"	6"	16-1/2"	1"	8-7/16"	2-1/2"	7/8"	1/2"	99.0
LI-10	1-1/4"	6"	2-1/2"	8-9/16"	3/4"	4-1/2"	--	1/2"	3/8"	18.0
LI-16	2"	7-1/2"	3-1/2"	8-7/8"	7/8"	6"	--	5/8"	1/2"	24.0
LI-24	3"	10-1/2"	4-1/2"	13-1/4"	1"	8-7/16"	2-1/2"	5/8"	1/2"	58.0
LI-32	4"	10-1/2"	5-1/2"	13-1/4"	1"	8-7/16"	2-1/2"	7/8"	1/2"	74.0

**SIZING:** see page 7 - **MOUNTING:** see page 8 - **ACCESSORIES:** see page 9



# PNEUMATIC PISTON VIBRATORS

## Series 2000

### CONSTRUCTION AND OPERATION

The Series 2000 piston vibrators include an internal spring and a moly coat to reduce the need for additional lubrication.

### AIR CUSHIONED (-AC) VIBRATORS

This model is utilized in area where noise is objectionable and may affect production. When used in place of an impacting model the next larger size should be used.

### HIGH TEMPERATURE (-HT) OPTION

This option is used in applications where the temperature exceeds 250°F and extends the maximum operating temperature to 400°F.

### EXHAUST MANIFOLD WITH MUFFLER/DUST PROOFER (-EMM) OPTION

This option is used to reduce the noise of the exhaust air and prevent contaminants from entering the vibrator when not in use.

### VIBRATOR OPTIONS FOR THESE UNITS:

- EMM Exhaust Manifold w/ Muffler/Dust Proofer
- HT High Temperature

## Series 2000

### SINGLE ATTACHING HEAD VIBRATOR

An industrial standard, this popular vibrator is utilized in a variety of applications including pattern transfer, materials flow and powder compaction. The high-frequency and high-impact energy developed by these vibrators results in greater operational efficiency. Maximum operating pressure 80 psi.

6 Models:

- 2005
- 2006
- 2008
- 2010
- 2012
- 2016



Model 2008

## Series 2100

### END INLET VIBRATOR

An adaptation of the Series 2000, the Series 2100 adds the advantage of end inlet porting. It is equipped with a swivel fitting, eliminating hose connection difficulties, both during assembly and when in use. Maximum operating pressure 80 psi.

4 Models:

- 2105
- 2106
- 2108
- 2110



Model 2108

## Series 2200

### DOUBLE ATTACHING HEAD VIBRATOR

Attachable at both ends, Series 2200 vibrators provide increased vibrating efficiency through greater energy transfer. The units are designed to provide dependable service even under extreme operating conditions and their non-plugging channels guarantee high vibratory performance. Maximum operating pressure 80 psi.

6 Models:

- 2205
- 2206
- 2208
- 2210
- 2212
- 2216



Model 2208

## Series 2300

### PIN TYPE VIBRATOR

Pin type vibrators afford excellent portability at reduced cost. They are ideal for use on match plates, molding equipment, concrete forms and applications where frequency removal or relocation of the vibrator is necessary. Maximum operating pressure 80 psi.

4 Models:

- 2306
- 2308
- 2310
- 2312



Model 2308

## Series 2400

### STUD MOUNT VIBRATOR

Versatile stud mounting is used in a wide variety of applications including match plates, material flow and compaction. High frequency and impact energy results in greater operational efficiency.

4 Models:

- 2408
- 2410
- 2412
- 2416



Model 2408

## Series 2600, 2800

### MOLDING AND CORE MACHINE VIBRATOR

These foundry machine vibrators assure consistent cores. They are heavy-duty, powerful and operate with a minimum of maintenance. These two series are constructed from ductile iron for superior strength and dependability.

4 Models:

- 2608
- 2610
- 2612
- 2812



Model 2608



Model 2812

# PNEUMATIC PISTON VIBRATORS



## PERFORMANCE

Series 2000 impacting

MODEL	PISTON DIA.	40 PSI		60 PSI		80 PSI	
		VPM	CFM	VPM	CFM	VPM	CFM
--05	5/8"	11000	5.5	17000	9.6	21000	12.6
--06	3/4"	13500	4.1	20000	6.4	22000	8.1
--08	1"	9000	2.7	14000	4.0	16000	5.4
--10	1-1/4"	4500	5.5	5800	8.0	6500	10.8
--12	1-1/2"	4500	4.1	6000	7.2	6800	9.9
--16	2"	4250	7.5	5600	12.7	6000	17.0

Series 2000 air cushioned

40 PSI		60 PSI		80 PSI	
VPM	CFM	VPM	CFM	VPM	CFM
5400	2.7	5500	4.0	5600	5.4
4100	2.7	4600	4.0	5100	5.4
4100	3.8	4800	4.8	5500	6.3
2000	5.5	2500	8.0	2800	10.8
2000	4.8	2250	7.2	2600	9.0
1900	6.1	2400	10.4	2850	13.5

## DIMENSIONS

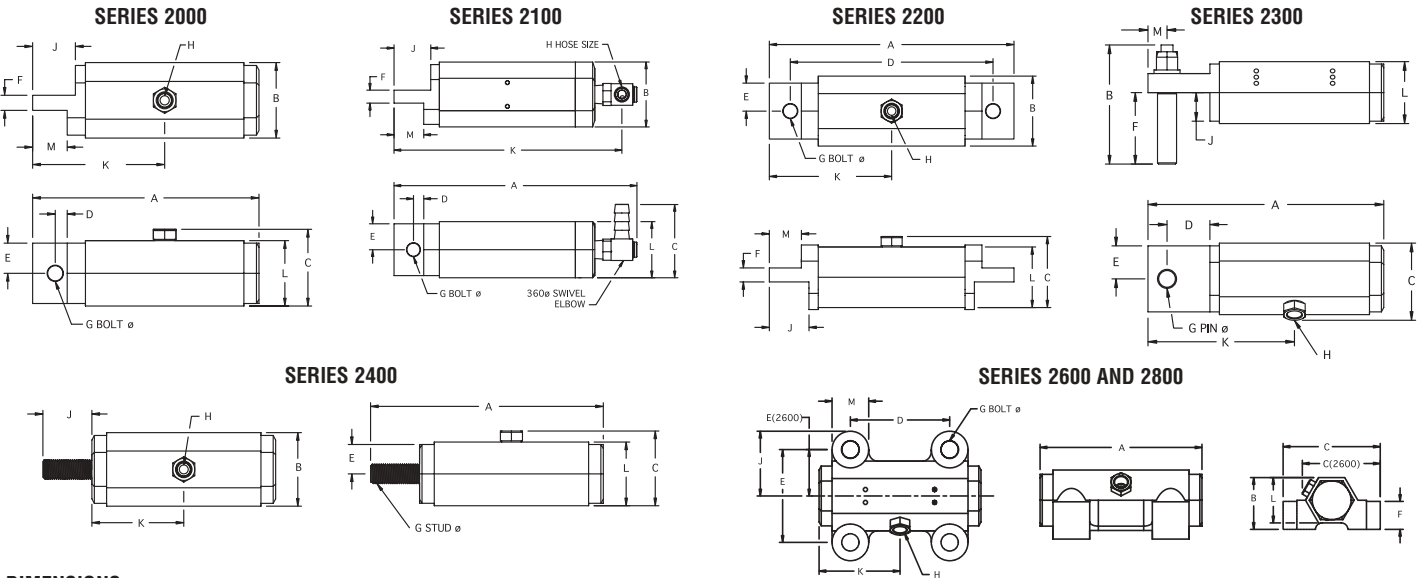

## DIMENSIONS

MODEL	PISTON SIZE	A	B	C	D	E	F	BOLT DIA. G	PORT NPT H	J	K	L	M	WEIGHT LBS.
2005	5/8"	5-1/2"	1-5/16"	1-7/16"	5/16"	1/2"	3/8"	5/16"	1/8"	15/16"	3-3/16"	1-1/8"	3/4"	1.5
2006	3/4"	5-1/2"	1-5/8"	1-11/16"	5/16"	5/8"	3/8"	3/8"	1/8"	15/16"	3-3/16"	1-3/8"	3/4"	2.3
2008	1"	5-5/8"	1-7/8"	1-15/16"	5/16"	3/4"	3/8"	3/8"	1/8"	1-1/16"	3-5/16"	1-5/8"	7/8"	3.3
2010	1-1/4"	9-1/4"	2-5/16"	2-5/16"	7/16"	13/16"	7/8"	1/2"	1/4"	1-3/8"	5-1/4"	2"	1-1/8"	7.3
2012	1-1/2"	9-5/16"	2-7/8"	2-13/16"	1/2"	1"	7/8"	5/8"	1/4"	1-7/16"	5-5/16"	2-1/2"	1-1/8"	11.5
2016	2"	9-7/8"	3-1/2"	3-3/8"	13/16"	1-1/4"	15/16"	7/8"	1/4"	2-1/16"	5-15/16"	3"	1-9/16"	17.0
2105	5/8"	6-13/16"	1-5/16"	1-7/8"	5/16"	1/2"	3/8"	5/16"	3/8"	15/16"	6-7/16"	1-1/8"	3/4"	1.3
2106	3/4"	6-13/16"	1-5/8"	2"	5/16"	5/8"	3/8"	3/8"	3/8"	15/16"	6-7/16"	1-3/8"	3/4"	2.3
2108	1"	7-1/16"	1-7/8"	2-1/8"	5/16"	3/4"	3/8"	3/8"	3/8"	1-1/16"	6-5/8"	1-5/8"	7/8"	3.3
2110	1-1/4"	10-7/16"	2-5/16"	2-5/16"	7/16"	13/16"	7/8"	1/2"	3/8"	1-3/8"	10-1/16"	2"	1-1/8"	7.3
2205	5/8"	6-5/16"	1-5/16"	1-7/16"	5-7/16"	1/2"	3/8"	5/16"	1/8"	15/16"	3-3/16"	1-1/8"	3/4"	1.5
2206	3/4"	6-5/16"	1-5/8"	1-11/16"	5-7/16"	5/8"	3/8"	3/8"	1/8"	15/16"	3-3/16"	1-3/8"	3/4"	2.3
2208	1"	6-9/16"	1-7/8"	1-15/16"	5-7/16"	3/4"	3/8"	3/8"	1/8"	1-1/16"	3-5/16"	1-5/8"	7/8"	3.5
2210	1-1/4"	10-1/2"	2-5/16"	2-5/16"	9-1/8"	13/16"	7/8"	1/2"	1/4"	1-3/8"	5-1/4"	2"	1-1/8"	7.5
2212	1-1/2"	10-5/8"	2-7/8"	2-13/16"	9-1/2"	1"	7/8"	5/8"	1/4"	1-7/16"	5-5/16"	2-1/2"	1-1/16"	12.5
2216	2"	11-13/16"	3-1/2"	3-3/8"	10-1/4"	1-1/4"	15/16"	7/8"	1/4"	2-1/16"	5-15/16"	3"	1-9/16"	19.3
2306	3/4"	6-3/16"	3-5/16"	1-11/16"	1-1/8"	3/4"	1-7/8"	1/2"	1/8"	1/2"	3-7/8"	1-3/8"	1/2"	2.5
2308	1"	6-3/16"	3-5/16"	1-15/16"	1-1/8"	7/8"	1-7/8"	1/2"	1/8"	3/4"	3-7/8"	1-5/8"	1/2"	3.5
2310	1-1/4"	9-1/4"	4-7/8"	2-5/16"	3/4"	13/16"	3"	1"	1/4"	9/16"	5-1/4"	2"	5/8"	7.5
2312	1-1/2"	9-1/4"	4-7/8"	2-13/16"	3/4"	1"	3"	1"	1/4"	13/16"	5-1/4"	2-1/2"	5/8"	12.0
2408	1"	6"	1-7/8"	1-15/16"	-	3/4"	-	1/2"	1/8"	1-1/4"	2-3/8"	1-5/8"	-	3.5
2410	1-1/4"	9-3/8"	2-5/16"	2-5/16"	-	13/16"	-	5/8"	1/4"	1-3/8"	4"	2"	-	7.5
2412	1-1/2"	9-3/8"	2-7/8"	2-13/16"	-	1"	-	5/8"	1/4"	1-3/8"	4"	2-1/2"	-	12.5
2416	2"	9-7/8"	3-1/2"	3-3/8"	-	1-1/4"	-	7/8"	1/4"	1-7/8"	4"	3"	-	19.3
2608	1"	4-3/4"	2"	3"	2-7/8"	1-3/8"	1-1/8"	1/2"	1/8"	1-7/8"	2-3/8"	1-3/4"	1-1/16"	4.5
2610	1-1/4"	8"	1/16"	3-11/16"	3-3/4"	1-11/16"	1-3/8"	1/2"	1/4"	2-5/16"	4"	2-1/8"	1-1/4"	8.5
2612	1-1/2"	8"	2-3/4"	4-1/8"	4"	1-15/16"	1-1/2"	5/8"	1/4"	2-9/16"	4"	2-3/8"	1-1/4"	10.5
2812	1-1/2"	9"	2-1/2"	5-5/8"	5-1/2"	3-7/8"	3/4"	5/8"	1/4"	2-13/16"	4-1/2"	2-3/8"	1-3/4"	14.5



# PNEUMATIC PISTON VIBRATORS

Series 3800

## CONCRETE FORM VIBRATOR

Three sizes of pneumatic vibrators provide high impact for efficient casting of concrete forms, septic tanks and similar case structures made with low moisture mixtures.



Model 3810

Attaching Head Detail

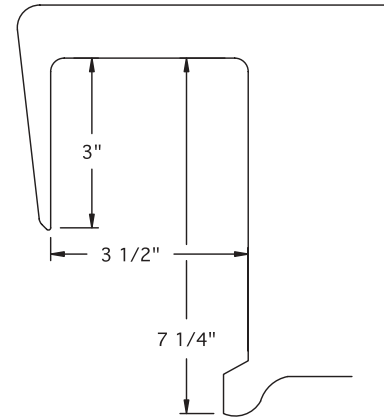

### PERFORMANCE

Series 3800

MODEL	PISTON DIA	CUBIC CONTENT OF MOLD	APPROX WEIGHT LBS	REPLACEMENT VIBRATOR MODEL #
3810	1-1/4"	4 CUBIC FT.	20	2210
3812	1-1/2"	8 CUBIC FT.	35	2212
3816	2"	16 CUBIC FT.	42	2216

Series 4200

## WEDGE HEAD VIBRATORS

This portable pneumatic vibrator provides high impact energy to ensure placement of concrete within intricately shaped as well as standard type forms. The handle is an integral part of the cast head. Order bracket 891005 for all 4200 series models.

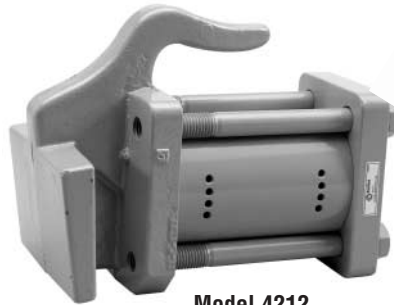

Model 4212



Bracket 891005

### PERFORMANCE

Series 4200

MODEL	PISTON DIA	APPROX. WEIGHT LBS	40 PSI		60 PSI		80 PSI		INLET PORT
			VPM	CFM	VPM	CFM	VPM	CFM	
4212	1-1/2"	21	2800	5.3	3500	8.1	4100	10.9	1/4"
4216	2"	26	2600	11.0	3900	16.1	4100	20.9	1/4"
4224	3"	55	2100	10.2	2600	16.7	3000	22.4	1/2"

Series 4400

## RAILROAD CAR SHAKEOUT VIBRATORS

Fast and efficient unloading of sand, cement, grain, coal, ores, chemicals, plastics or other difficult to move materials. 4424L high amplitude car shaker is for the removal of more difficult high-density materials. Order bracket 891006 for all 4400 series models.

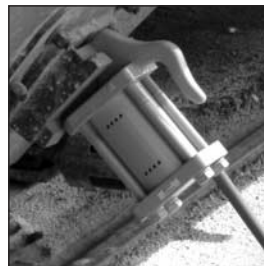

Model 4424



Bracket 891006

### PERFORMANCE

Series 4400

MODEL	PISTON DIA	FORCE LBS	APPROX. WEIGHT LBS	40 PSI		60 PSI		80 PSI		INLET PORT
				VPM	CFM	VPM	CFM	VPM	CFM	
4424	3"	2400	40	2100	10.2	2600	16.7	3000	22.4	1/2"
4424L	3"	3200	60	850	13.6	1000	24.7	1250	35.9	1/2"
4432	4"	3800	73	1200	19.1	1700	31.8	1900	40.3	1/2"

ACCESSORIES: see page 9

Series GT  
**GRID TAMPERS**

Cougar Tampers provide panel manufacturers a fast means of densifying very low slump concrete for high strength in plain, escalated and exposed concrete panels. All GT models available with curved grids for special applications. For additional information consult factory.

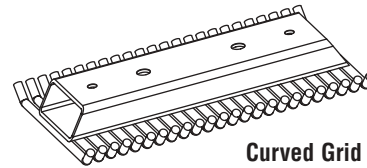

Curved Grid



Model GT-25

**PERFORMANCE**  
Series GT

MODEL	PISTON DIA	APPROX. WEIGHT LBS	PLATE/GRID DIMENSIONS	40 PSI		60 PSI		80 PSI		INLET PORT
				VPM	CFM	VPM	CFM	VPM	CFM	
GT-15/GT-15-C	1-1/4"	22	8" x 12"	4600	6.1	5800	8.8	6500	11.6	1/4"
GT-25/GT-25-C	2"	50	12" x 18"	2600	11.0	3900	16.1	4100	20.9	3/8"
GT-25L/GT-25L-C	2" L	55	12" x 18"	1400	6.8	2600	12.8	8500	19.7	3/8"

ACCESSORIES: see page 9

## SIZING FLANGE PISTONS



The following information is provided as a guide to selecting the proper flange mount piston vibrator for your application. For accurate sizing and recommendations, contact your local Cougar Representative or Cougar Industries, Inc.

### INFORMATION REQUIRED TO SIZE PISTON VIBRATORS FOR A HOPPER

- Dimensions of the sloped portion of the hopper—length, width and height, or the diameter if round
- Material density in lbs./cu. ft.
- Determine if the material is “wet” (more than 2% moisture)
- Hopper wall thickness

### Calculate the weight of the material in the sloped portion of the hopper

- For round hoppers use the calculation  $0.261 \times \text{dia.}^2 \times \text{height}$  (sloped portion only)  $\times$  weight per cubic foot of material.
- For square or rectangular hoppers: Length  $\times$  width  $\times$  height (sloped portion only)  $\times$  1/3  $\times$  weight per cubic foot of material.

### Review the vibrator selection chart

- Match the calculated weight to the chart. Read the proper size vibrator at the right side of the chart.

### Special considerations

- If your hoppers' wall thickness is less than the minimum wall thickness on the chart, use 2 vibrators of the next size smaller.
- If your material has more than 2% moisture content, select the next larger vibrator.
- Low density, high surface area materials require high amplitude vibrators. (5016L, 5024L or 5032L) Refer to page 2.
- When air cushioned (-AC) models are required, use the next size larger vibrator.
- For mounting and control accessories, see page 9.

### RECOMMENDED VIBRATOR MODELS FOR VARIOUS HOPPER CAPACITIES & WALL THICKNESS

WEIGHT OF MATERIAL IN THE SLOPED PORTION OF THE HOPPER IN LBS.	WALL THICKNESS OF THE HOPPER	MODEL	PISTON SIZE
up to 400 lbs.	1/8"	5008	1"
400 to 1,000 lbs.	1/8"	5010	1-1/4"
1,000 to 4,000 lbs.	1/8" to 3/16"	5012	1-1/2"
4,000 to 10,000 lbs.	3/16" to 1/4"	5016	2"
8,000 to 20,000 lbs.	5/16" to 3/8"	5016L	2" L
10,000 to 30,000 lbs.	5/16" to 3/8"	5024	3"
20,000 to 50,000 lbs.	3/8" to 1/2"	5024L	3" L
40,000 to 70,000 lbs.	3/8" to 1/2"	5032	4"
over 70,000 lbs.	1/2" to 3/4"	5032L	4" L



Series 2700

**VIBRA-TAMPERS**

This tamper facilitates densification and fast finishing of special panels using low moisture concrete. Includes 1/4" NPT hand air valve.



**Model 2708**

**PERFORMANCE**

Series 2700

MODEL	PISTON DIA	APPROX. WEIGHT LBS	PLATE/GRID DIMENSIONS	40 PSI		60 PSI		80 PSI		INLET PORT
				VPM	CFM	VPM	CFM	VPM	CFM	
2708	1"	6	5" x 6"	9000	2.7	14000	4.0	16000	5.4	1/4"

**ACCESSORIES:** see page 9

**MOUNTING POSITIONS**



To obtain maximum efficiency from pneumatic piston vibrators, correct location is important. For free-flowing bulk material installation, vibrators on hoppers should operate only when the hopper is open to flow. Otherwise, packing of material can result.

**NOTE:** Always mount the vibrator on a mounting plate or channel iron, never directly to the skin of the bin.



**CURVED SURFACES**

To mount a vibrator to a curved surface, select a bracket made from a channel section or bent plate. Mounting bolt heads can be welded to the bracket's underside.

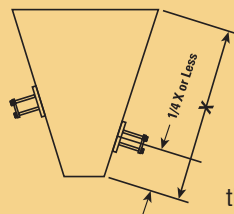

**RECTANGULAR HOPPERS**

Mount each vibrator and mounting channel as with a conical hopper or a curved surface. If a stiffener obstructs mounting, mount the vibrator in the middle of the panel next to the stiffener. If required, a second vibrator should be bolted on the opposite face at a slightly higher elevation, approximately 1/3 of the slope length from the discharge.

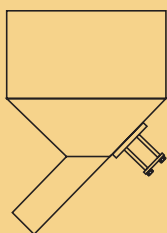

**HOPPER WITH SLOPING DISCHARGE**

Mount the vibrator on the centerline of the hopper, as close to the discharge as possible. An additional vibrator may be required on the discharge chute.

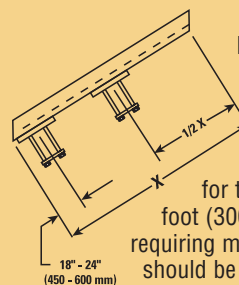

**INCLINED CHUTES**

Chutes less than 10 to 12 feet (3 to 3.6m) long are usually equipped with just one vibrator located well below the center. Allow for the vibrator to be moved about one foot (300mm) in either direction. On chutes requiring more than one vibrator, the first one should be located 18 to 24 inches (450 to 600mm) from the outlet. The second one should be mounted about halfway between the first vibrator and the upper end.

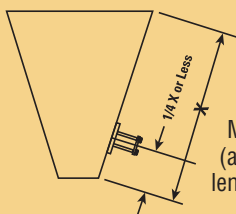

**CONICAL HOPPERS**

Mount the vibrator to the hopper (as shown) 1/4 or less of the slope length from the discharge.



## ACCESSORIES



Typical Piping Arrangement

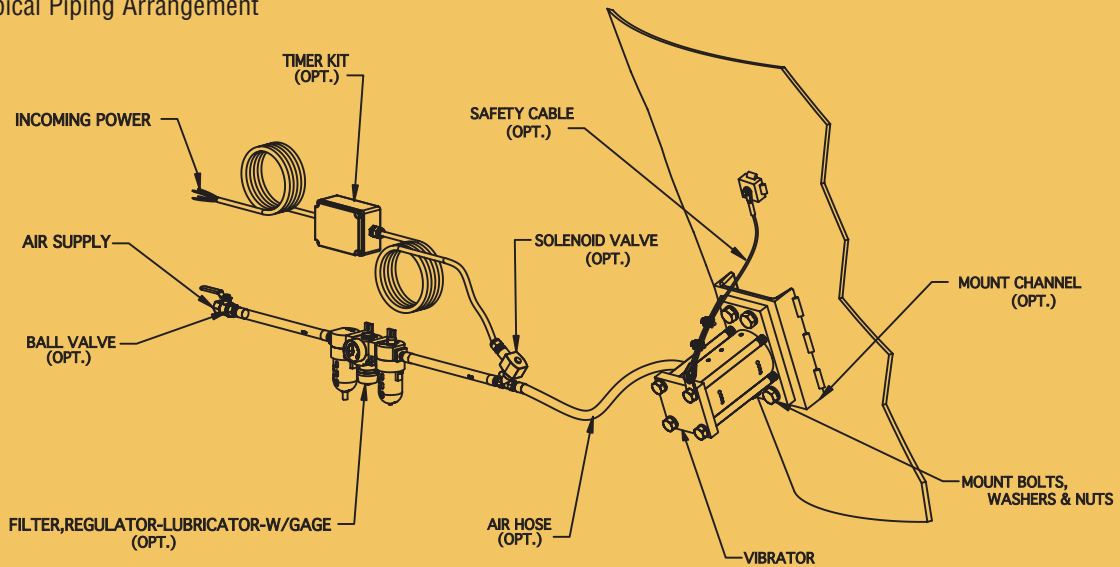

### ACCESSORIES

Series 5000 & LI

MODEL	PISTON DIA	INSTALLATION/ OPERATION KIT (1)	MOUNTING KIT (2)	SAFETY CABLE ASSY (3)	HOSE SIZE	HOSE ASSY (4)	HOSE BY FOOT	SOLENOID VALVE	F-R-L (5)	TIMER (6)	BALL VALVE
5008	1"	--	891000	220316	1/4"	607004	605003	193757	601069	197253	606003
5010	1-1/4"	--	891001	220316	3/8"	607005	605004	193753	601022	197253	606004
5012	1-1/2"	--	891002	220316	3/8"	607005	605004	193753	601022	197253	606004
5016	2"	--	891002	220316	3/8"	607005	605004	193753	601022	197253	606004
5016L	2"L	--	891002	220316	3/8"	607005	605004	193753	601022	197253	606004
5024	3"	--	891003	220317	1/2"	607006	605005	193754	601041	197253	606009
5024L	3"L	--	891003	220317	1/2"	607006	606005	193754	601041	197253	606009
5032	4"	--	891004	220317	1/2"	607006	605005	193754	601041	197253	606009
5032L	4"L	--	891004	220318	1/2"	607006	606005	193754	601041	197253	606009
LI-10	1-1/4"	891250	891001	220316	1/2"	891300	605005	891200	601022	891500	606004
LI-16	2"	891251	891002	220316	1/2"	891301	605005	891201	601064	891500	606004
LI-24	3"	891252	891003	220317	1/2"	891301	605005	891201	601064	891500	606009
LI-32	4"	891253	891004	220317	1/2"	891301	605005	891201	601064	891500	606009

Series 2000

MODEL	PISTON DIA	HOSE SIZE	HOSE ASSEMBLY (4)	HOSE BY FOOT	SOLENOID VALVE	F-R-L (5)	TIMER (6)	BALL VALVE
--05	5/8"	1/4"	607004	605003	193757	601069	197253	606003
--06	3/4"	1/4"	607004	605003	193757	601069	197253	606003
--08	1"	1/4"	607004	605003	193757	601069	197253	606003
--10	1-1/4"	3/8"	607005	605004	193753	601022	197253	606004
--12	1-1/2"	3/8"	607005	605004	193753	601022	197253	606004
--16	2"	3/8"	607005	605004	193753	601022	197253	606004

All Other

MODEL	PISTON DIA	MOUNTING KIT (2)	HOSE SIZE	HOSE ASSEMBLY (4)	HOSE BY FOOT	F-R-L (5)	BALL VALVE
3810	1-1/4"	--	3/8"	607005	605004	601022	606004
3812	1-1/2"	--	3/8"	607005	605004	601022	606004
3816	2"	--	3/8"	607005	605004	601022	606004
4212	1-1/2"	891005	3/8"	607005	605004	601022	606004
4216	2"	891005	3/8"	607005	605004	601022	606004
4224	3"	891005	1/2"	607006	606005	601041	606009
4424	3"	891006	1/2"	607006	605005	601041	606009
4424L	3"L	891006	1/2"	607006	606005	601041	606009
4432	4"	891006	1/2"	607006	605005	601041	606009
GT-15	1-1/4"	--	3/8"	607005	605004	601022	606004
GT-15-C	1-1/4"	--	3/8"	607005	605004	601022	606004
GT-25	2"	--	3/8"	607005	605004	601022	606004
GT-25-C	2"	--	3/8"	607005	605004	601022	606004
GT-25L	2"L	--	3/8"	607005	605004	601022	606004
GT-25L-C	2"L	--	3/8"	607005	605004	601022	606004
2708	1"	--	3/8"	607005	605004	601022	606004

- (1) **Installation kit includes:** solenoid hose assembly, mount channel, bolts, washers, nuts.
- (2) **Mounting kit includes:** mounting channel, bolts, washers, nuts (4000 series contain female bracket only)
- (3) **Safety cable assembly includes:** cable 77" lg., clips, thimble, bolt, washer & weld plate.
- (4) **Hose assembly includes:** hose (order per foot length) male NPT fittings either end. (LI units include quick connect)
- (5) **F-R-L includes:** filter-regulator-lubricator assembly with gage & mount
- (6) **Timer:** 891500 has a pulse rate of 14 to 172 blows per minute. Timer 197253 is adjustable 3-60 minutes on, 3-60 minutes off. For additional time ranges, consult factory.

**FOR ALL YOUR VIBRATORY NEEDS**



**ELECTRIC**  
HEAVY DUTY



**CANNON**  
ENERGY-EFFICIENT  
& NON-DESTRUCTIVE



**DC**  
DUMPING  
& SPREADING



**TURBINE**  
SMALL & POWERFUL



**BALL**  
SMALL & POWERFUL



**TABLES**  
STANDARD &  
CUSTOM MODELS

**COUGAR**  
INDUSTRIES, INC.

3600 Cougar Drive • Peru, Illinois 61354 • P: 815.224.1200  
F: 815.224.1241 • [www.cougarindustries.com](http://www.cougarindustries.com)  
For more information call Toll-Free: 800.262.2106