

COUGAR



Mobile Vibrators



- Models for any application
- 12/24 Volt Electric, Hydraulic or Pneumatic
- 80 to 3200 Pounds Force Output
- Made in America



COUGAR
INDUSTRIES, INC.

www.cougarindustries.com

Form SB-MOBILE-001

Cougar's complete line of rugged, durable Truck Vibrators are:

- Sealed against dirt, dust, and water for long life in extreme conditions.
- Shielded, oversized, permanently lubricated ball bearings assure exceptional service life.
- Small size and weight with High-speed, low-amp electric motors.
- Easy, low-cost installation
- Maximize vibration effectiveness - Truck Vibrators bolt to a mounting plate welded to the frame.

Increase your productivity -

- Eliminate carry-back
 - More payload per cycle
 - Fewer cycles per job
- Fewer cycles mean:
 - Lower labor and fuel costs
 - Reduced vehicle wear
- Faster dump times
- Material is more evenly distributed when spreading
- Eliminate bed cleanout time and personnel

Reduce common causes of equipment damage -

- Eliminate strain on hydraulic components lowering half-full beds
- Stop moving material by:
 - Tailgate banging
 - Slamming the brakes
 - "Popping" the clutch
- No need to clean out the bed with a backhoe - leaving more places for material to stick



Reduce operator risks associated with dumping and spreading cohesive materials -

- Keep the operator safe inside the cab - not on the bed of the truck
- Facilitate material flow to minimize possible "tip over" during spreading or dumping.

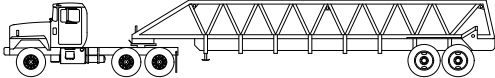
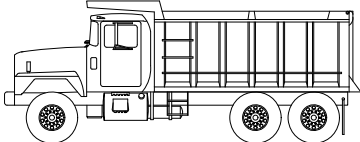
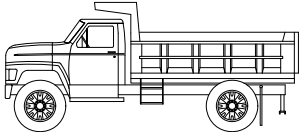
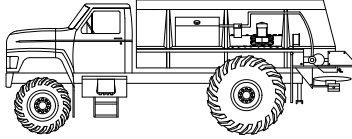
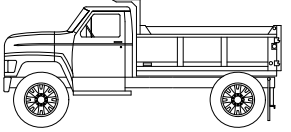
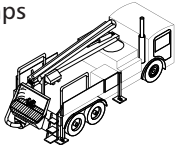
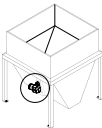
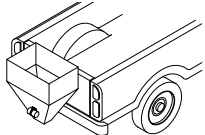

Selection Guide

Model Number	Body Length (ft)	Body Capacity (yd ³)	Body Style
DC-3200 NHD-110	15-40	15-30	Tandems/Live Bottoms/Multi-axes to 40' 
DC-3200 5016 NP-55 NP-75	10-15	8-16	Rear Dump 
DC-2500 DC-1600	9-10	5-10	Rear Dump 
DC-2500 DC-1600	10-15	7-10	Spreader Body 
DC-1600 DC-1000	8-9	2-5	Rear Dump 
DC-1000 DC1-400	7-8	1-2	Concrete Pumps Bins Hoppers Chutes  
DC-80 DC-200	NA	1	Rear Dump 

Easy Operation



A simple push of the button activates the vibrator. Hold for a few seconds until the load begins to move.

Installation Kit Included

Installation kits are shipped standard with the DC-1000 through the DC-3200. Each "DC" installation kit includes 25' of cable (40' w/ the DC-3200), mounting plate, bolts, washers, switch, solenoid, terminals, and installation instructions. Installation kits for the DC-80 and DC1-400 include mounting bolts and washers. Circuit breakers (optional) are recommended for all "DC" vibrators.

Pneumatic ring units NP-55 & NP-75 require a filter/regulator/lubricator in the air line.

Pneumatic piston unit 5016 requires a filter/regulator in the air line.

COUGAR



Simple Installation

Electric Installation

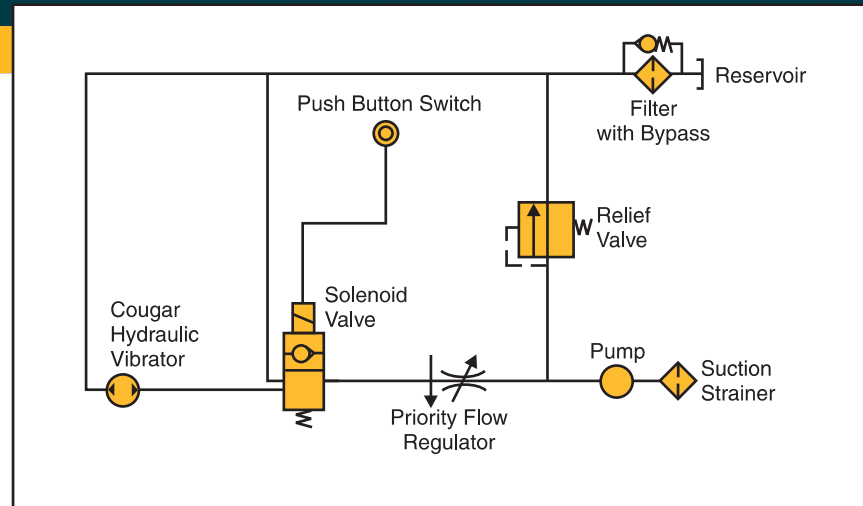
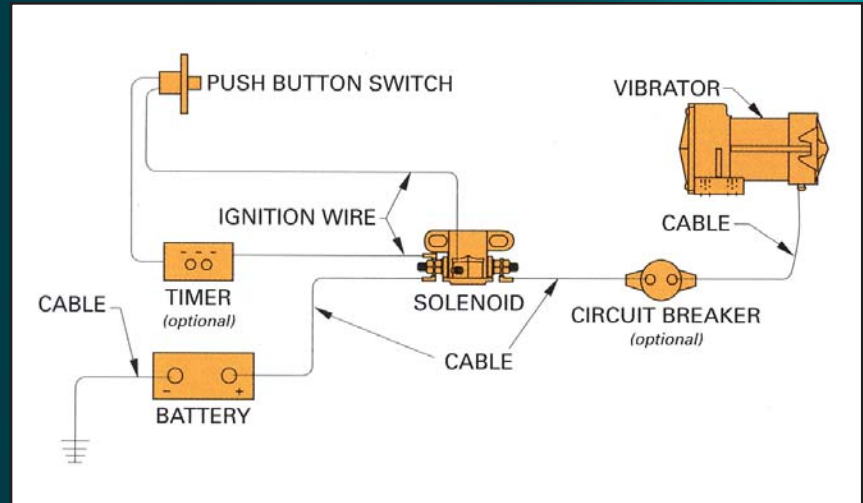

Hydraulic Installation

Optional Equipment

- Cable (by the foot)
- Circuit breaker
- Timer
- Timer Enclosure
- Continuous duty kit (DC-80, DC1-400, DC-1000)



COUGAR
INDUSTRIES, INC.

3600 Cougar Drive,
Peru, Illinois 61354-9336

Toll Free: 800-262-2106
Phone: 815-224-1200
Fax: 815-224-1241

www.cougarindustries.com

Form SB-DC/HT-001