

Concrete Vibrators

COUGAR



DIMENSIONS (Inch)

Model 3800

| Model | Piston Size | A | B | C | Port NPT | E | F | G | Weight Lbs. |
|-------|-------------|--------|-------|--------|----------|-------|-------|-------|-------------|
| | In | | | | D | | | | |
| 3810 | 1.250 | 18.750 | 3.063 | 11.250 | 1/4 | 3.375 | 3.500 | 7.500 | 28.250 |
| 3812 | 1.500 | 18.750 | 3.500 | 11.250 | 1/4 | 3.375 | 3.500 | 7.500 | 33.000 |
| 3816 | 2.000 | 18.750 | 4.125 | 11.250 | 1/4 | 3.375 | 3.500 | 7.500 | 40.000 |

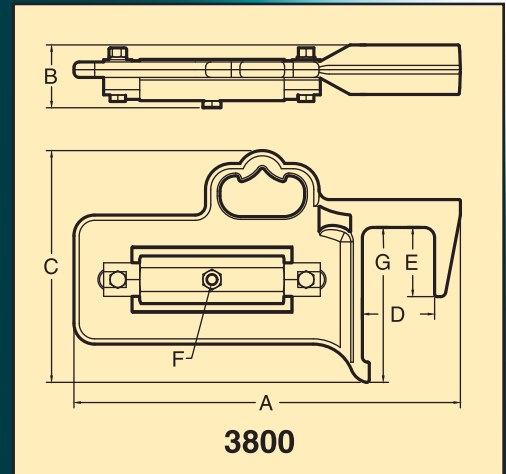

PERFORMANCE DATA

| Model | Piston Size In | 40 PSI | | 60 PSI | | MAX 80 PSI | | Content of Mold Cubic Feet | Replacement Vibrator Model # |
|-------|----------------|--------|-----|--------|------|------------|------|----------------------------|------------------------------|
| | | VPM | CFM | VPM | CFM | VPM | CFM | | |
| 3810 | 1.250 | 4500 | 5.5 | 5800 | 8.0 | 6500 | 10.8 | 4 | 2210 |
| 3812 | 1.500 | 4500 | 4.1 | 6000 | 7.2 | 6800 | 9.9 | 8 | 2212 |
| 3816 | 2.000 | 4250 | 7.5 | 5600 | 12.7 | 6000 | 17.0 | 16 | 2216 |

For the mounting and operation instructions on Concrete Vibrators see our form 714

Model 4200

| Model | Piston Size | 40 PSI | | 60 PSI | | MAX 80 PSI | |
|-------|-------------|--------|------|--------|------|------------|------|
| | In | VPM | CFM | VPM | CFM | VPM | CFM |
| 4212 | 1.500 | 2800 | 5.3 | 3500 | 8.1 | 4100 | 10.9 |
| 4216 | 2.000 | 2600 | 11.0 | 3900 | 16.1 | 4100 | 20.9 |
| 4224 | 3.000 | 2100 | 10.2 | 2600 | 16.7 | 3000 | 22.4 |

PERFORMANCE DATA

| Model | Piston Size | A | B | C | Port NPT | E | Weight Lbs. |
|-------|-------------|-------|-------|--------|----------|-------|-------------|
| | In | | | | D | | |
| 4212 | 1.500 | 7.437 | 3.500 | 9.625 | 1/4 | 2.313 | 16.250 |
| 4216 | 2.000 | 7.437 | 3.500 | 9.500 | 1/4 | 2.313 | 20.500 |
| 4224 | 3.000 | 7.437 | 3.500 | 11.000 | 1/2 | 2.313 | 42.000 |

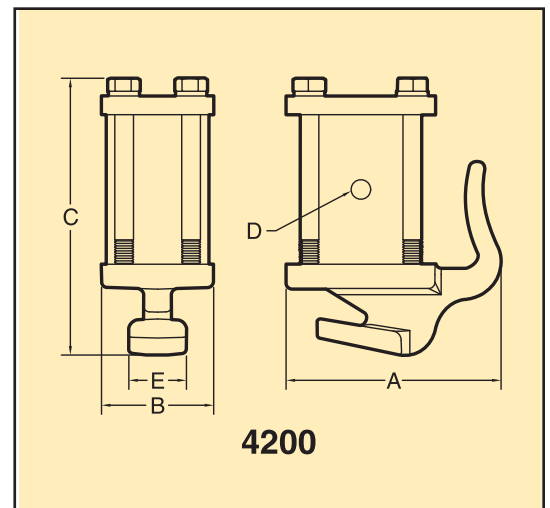

COUGAR
INDUSTRIES, INC.

3600 Cougar Drive,
Peru, Illinois 61354-9336

Toll Free: 800-262-2106
Phone: 815-224-1200
Fax: 815-224-1241

www.cougarindustries.com

Form TB-3800/4200-001a