

# Concrete Tampers

## Model GT

# COUGAR



DIMENSIONS (Inch)

Model	Piston Size	A	B	C	Port NPT	E	Weight Lbs.
	In				D		
GT-15/GT-15-C	1.250	13.87	8.000	31.125	1/4	12.000	22.000
GT-25/GT-25-C	2.000	21.313	12.000	31.875	1/4	18.000	50.000
GT-25-L/GT-25-L-C	2.000	21.313	12.000	31.875	1/4	18.00	55.000

*For the mounting and operation instructions on Piston Vibrators see our form 714*

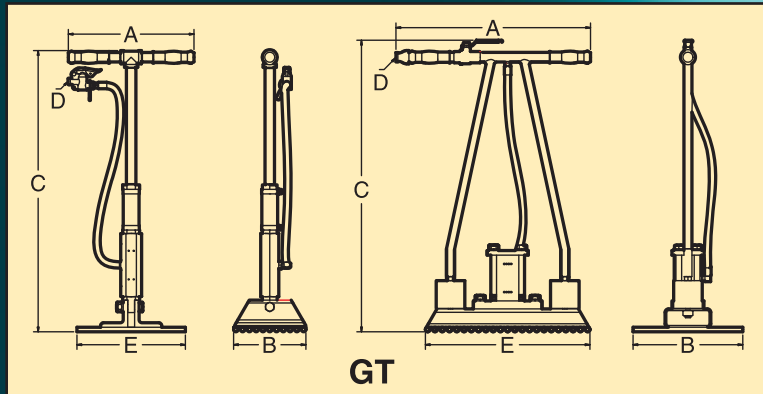

### PERFORMANCE DATA

Model	Piston Size	40 PSI		60 PSI		MAX 80 PSI	
	In	VPM	CFM	VPM	CFM	VPM	CFM
GT-15/GT-15-C	1.250	4500	5.5	5800	8.0	6500	10.8
GT-25/GT-25-C	2.000	2600	11	3900	16.1	4100	20.9
GT-25-L/GT-25-L-C	2.000	1400	6.8	2600	12.8	3500	19.7

## Model 2700

Model	Piston Size	A	B	C	Port NPT	E	Weight Lbs.
	In				D		
2708	1.000	8.875	5.000	5.875	1/4	6.000	6.250

*For the mounting and operation instructions on Piston Vibrators see our form 714*

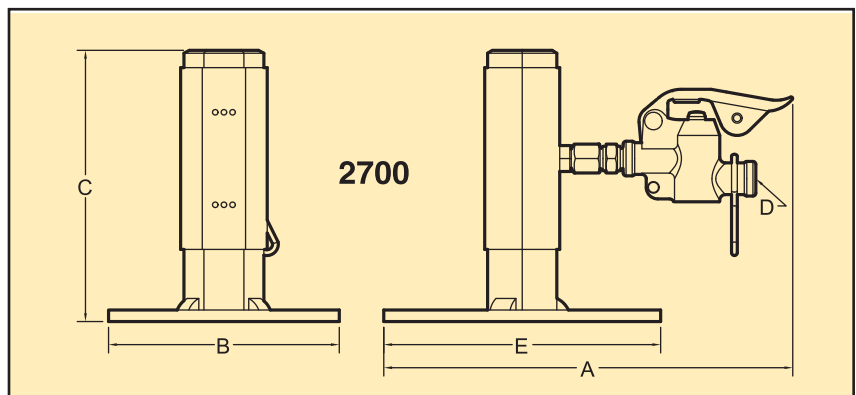

### PERFORMANCE DATA

Model	Piston Size	40 PSI		60 PSI		MAX 80 PSI	
	In	VPM	CFM	VPM	CFM	VPM	CFM
2708	1.000	9000	2.7	14000	4.0	16000	5.4



**COUGAR**  
INDUSTRIES, INC.

3600 Cougar Drive,  
Peru, Illinois 61354-9336

Toll Free: 800-262-2106  
Phone: 815-224-1200  
Fax: 815-224-1241

[www.cougarindustries.com](http://www.cougarindustries.com)

Form TB-GT/2700-001a