

# Piston Vibrators Model LI

# COUGAR



DIMENSIONS (Inch)

Model	Piston Size	A	B	C	Bolt Pattern		Bolt Size	Port NPT	Weight Lbs.
	In				D	E			
LI-10	1.25	6.0	2.5	8.563	4.500	--	1/2	3/8	18
LI-16	2.00	7.5	3.5	8.875	6.000	--	5/8	1/2	24
LI-24	3.00	10.5	4.5	13.250	8.438	2.5	5/8	1/2	58
LI-32	4.00	10.5	5.5	13.250	8.438	2.5	7/8	1/2	74

For the mounting and operation instructions on Piston Vibrators see our form 714

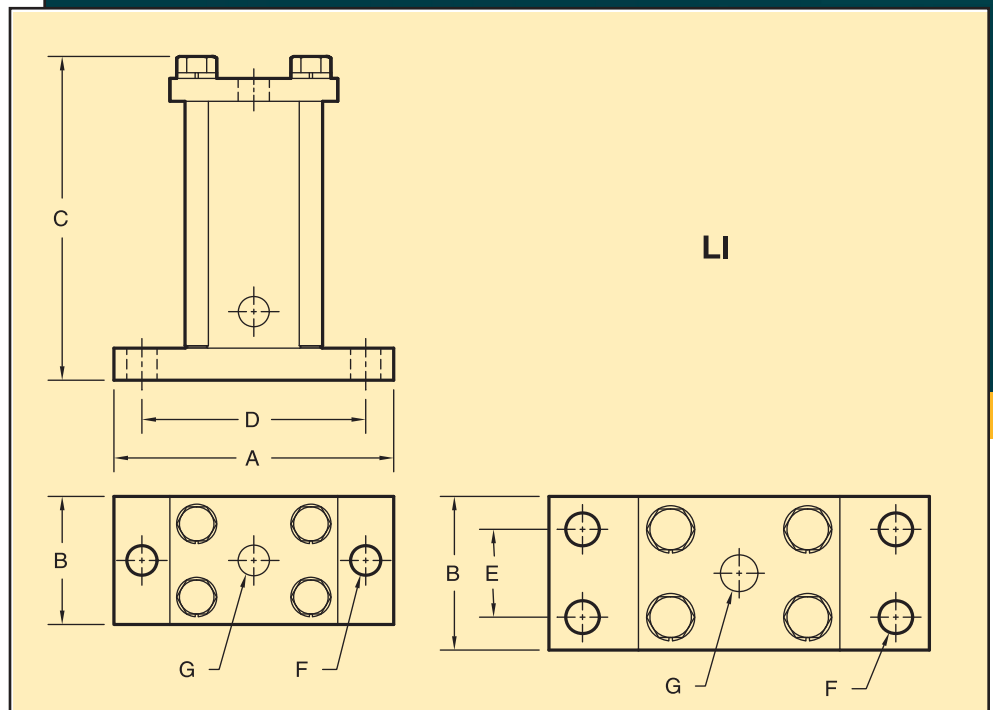

An interchange chart for competitive models is available

## PERFORMANCE DATA

Model	Piston Size	Kinetic Energy Ft lbs at 80 PSI	Pulse Rate Min/Max	MAX 80 PSI
	In			Cu.Ft./Stroke
LI-10	1.25	14	14/172	0.014
LI-16	2.00	48	14/172	0.019
LI-24	3.00	98	14/172	0.049
LI-32	4.00	252	14/172	0.110



**COUGAR**  
INDUSTRIES, INC.

3600 Cougar Drive,  
Peru, Illinois 61354-9336

Toll Free: 800-262-2106  
Phone: 815-224-1200  
Fax: 815-224-1241

[www.cougarindustries.com](http://www.cougarindustries.com)

Form TB-LI-001a