

Piston Vibrators Model LI

COUGAR



DIMENSIONS (Millimeter)

Model	Piston Size	A	B	C	Bolt Pattern		Bolt Size	Port NPT	Weight kg
	mm				D	E			
LI-10	32	152	64	217	114	--	13	3/8"	8.2
LI-16	51	191	89	225	152	--	16	1/2"	10.9
LI-24	76	267	114	337	214	64	16	1/2"	26.3
LI-32	102	267	140	337	214	64	22	1/2"	33.6

For the mounting and operation instructions on Piston Vibrators see our form 714

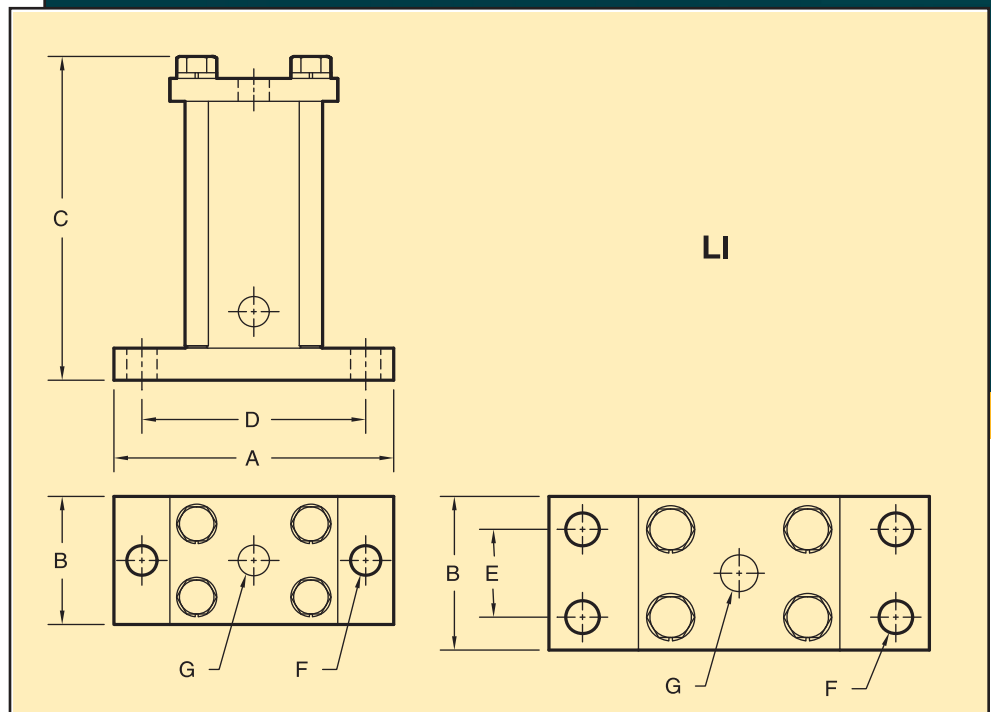

An interchange chart for competitive models is available

PERFORMANCE DATA

Model	Piston Size	Kinetic Energy N m at 5.5 Bar	Pulse Rate Min/Max	MAX 5.5 Bar
	mm			Liter/Stroke
LI-10	32	19	14/172	0.396
LI-16	51	65	14/172	0.538
LI-24	76	133	14/172	1.388
LI-32	102	342	14/172	3.115



COUGAR
INDUSTRIES, INC.

3600 Cougar Drive,
Peru, Illinois 61354-9336

Toll Free: 800-262-2106
Phone: 815-224-1200
Fax: 815-224-1241

www.cougarindustries.com

Form TB-LI-001b